



Feature

- 250 amps continuous carry
- Hermetically sealed with hydrogen gas, the arc is not exposed. Be able to use in explosive & harsh environments without oxidation or contamination of contacts
- Contacts' part meet protection degree
- Not position sensitive- can be mounted in any position for ease of installation
- RoHS compliant
- Auxiliary Contact: 1 Form A

Feature

- UL/CUL File No: E179745-1-44
- CE File No: N8A 124740 0004

Contact Data

Item	Specification
Contact arrangement	Power Contact:1 Form A Auxiliary Contact:1 Form A
Rated current	250A
Contact resistance	$\leq 0.3\text{m}\Omega$ (@ 250A)
Min.Switching load	12VDC 1A
Max. Switching voltage	1500VDC
Max. Breaking current	2000A (1000VDC, 1 cycle)
Max. Short Circuit Current	No smoke, no fire at 8000A(5ms)
Electrical endurance	Breaking:1500VDC, 20A 15000 cycles
	Breaking:1500VDC, 80A 500 cycles
	Breaking:1000VDC, 250A 1000 cycles
	Breaking:1500VDC, 250A 100 cycles
	Breaking:1000VDC, 2000A 1 cycles
	Breaking:1500VDC, 1000A 1 cycles

Parameters Table

Item	Information
Mechanical life	2×10^5 cycles
Insulation resistance	1000M Ω (2500VDC)
Dielectric strength	Between open contacts 4000VAC 1min 1mA
	Between contact and coil 4000VAC 1min 1mA
	Between main and auxiliary contacts 4000VAC 1min 1mA
Absorption time (at rated coil voltage)	$\leq 30\text{ms}$
Release time (at rated coil voltage)	$\leq 10\text{ms}$
Shock resistance	Functional 98m/s ² (10G)
	Destructive 490m/s ² (50G)
Vibration resistance	10Hz~55Hz 49m/s ² (5G)
Ambient temperature	-40°C~+85°C
Ambient humidity	5%~85% RH
Weight	350g \pm 20g
External dimension	88.8.0 \times 43.0 \times 83.3

CoilData

Room temperature 23°C

Rated voltage (VDC)	Operation voltage (VDC)	Max. voltage (VDC)	Pick-up voltage (VDC)	Drop-out voltage (VDC)	Coil resistance (±10%)(Ω)	Operating power (inrush, W)	Operating power (stable, W)
12	12	16	≤9.6	≥1.2	Starting coil:4.8 Holding coil:24.0	36.0	6.0
24	24	32	≤19.2	≥2.4	Starting coil:19.2 Holding coil:96.0	36.0	6.0

NOTES:

- (1) Unless specified otherwise, ambient temperature: 23°C, on:off / 0.6s : 5.4s.
- (2) If other types of rated coil voltage is needed, please contact us.

Reference data

- Safe Operation Temperature
- Functional Temperature
- - - Short-circuit Capacity Curve

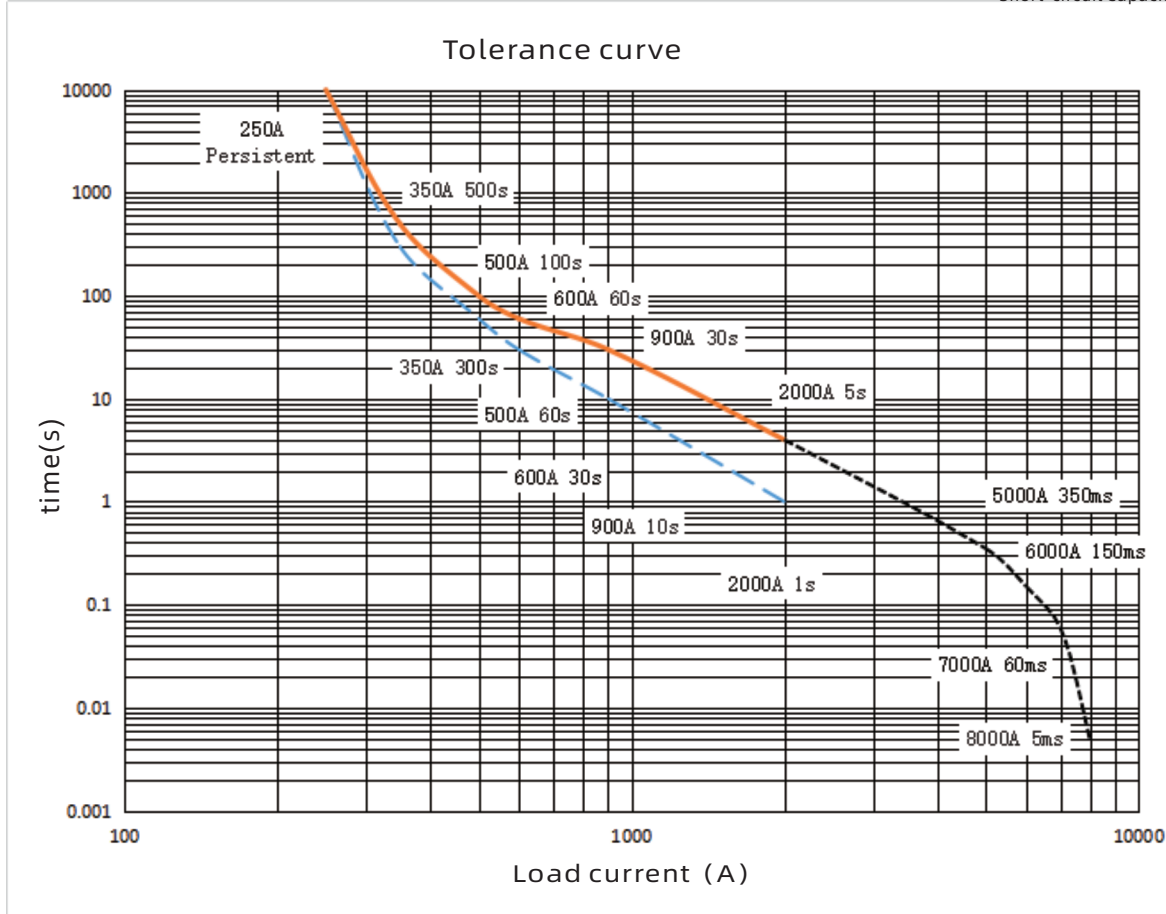

NOTE:

- (1) The upper limit of safety temperature is 180°C, upper limit of functional temperature is 150°C ;
- (2) Ambient temperature is 85°C, wire cross sectional area ≥80mm²; (Test conditions for this curve)
- (3) The data greater than 2000A is the data of short circuit resistance of relay. The relay can guarantee no fire or explosion within this curve. When the current is greater than 6000A, the relay contact may be repulsed by a large current.

Ordering Information

Nomenclature

SEP	250W	-		M	F		2	
Customer special code Nil: No customer special requirement								
Numbers or Letters: Customer special requirement								
Load connection type							2: internal thread	
Coil voltage							12: 12VDC 24: 24VDC	
Auxiliary contact							F: 1 Form A	
Contact arrangement							M: 1 Form A	
Voltage rating							1000: 1000VDC 1500: 1500VDC	
Installation							V: Vertical installation	
Load current							250W: 250A	
Type designation							SEP	

Packing style: 36/box

Outline Dimensions

SEP250W-XXXXMFXX2

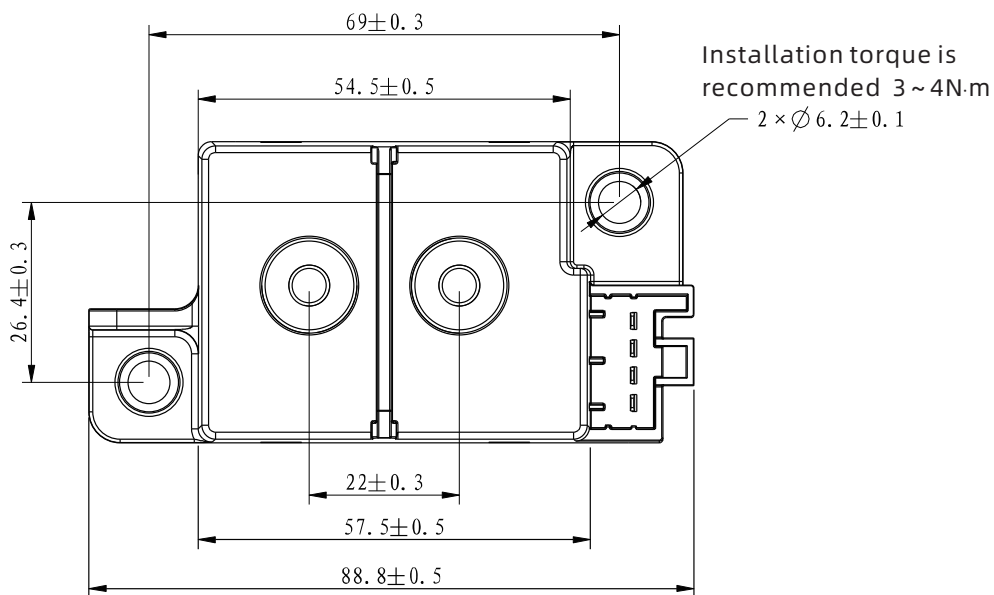
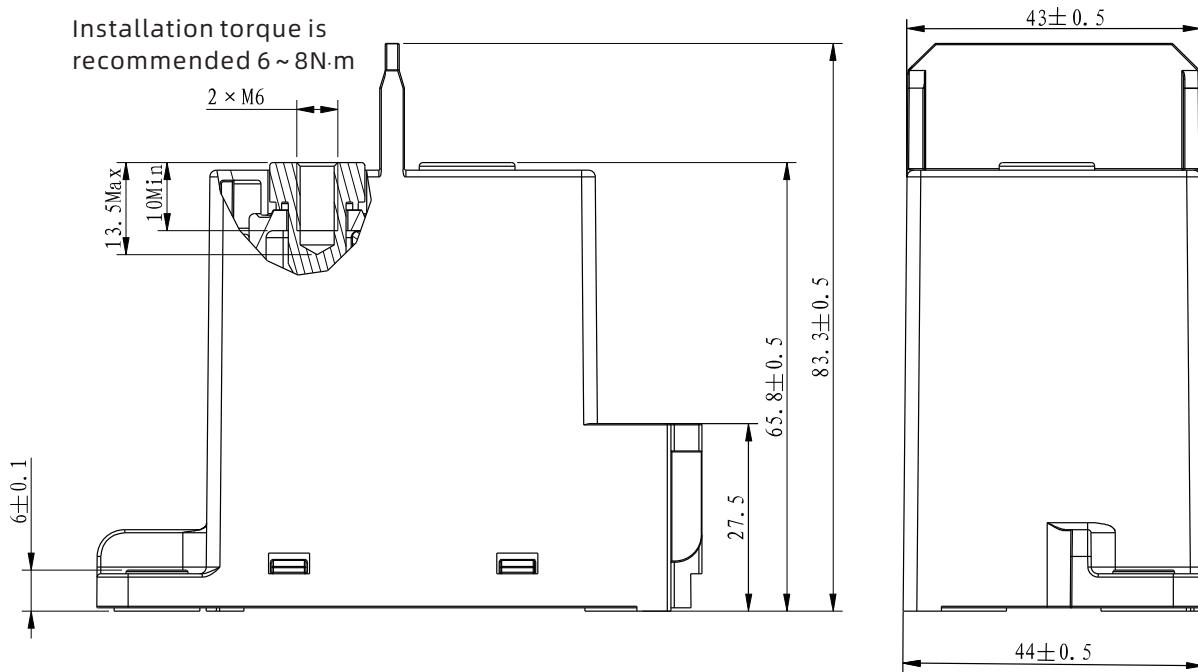

Coil Connection Type

Connectors: Yazaki: 7283-1044 or Tianhai:0488701(Customer self configuration)

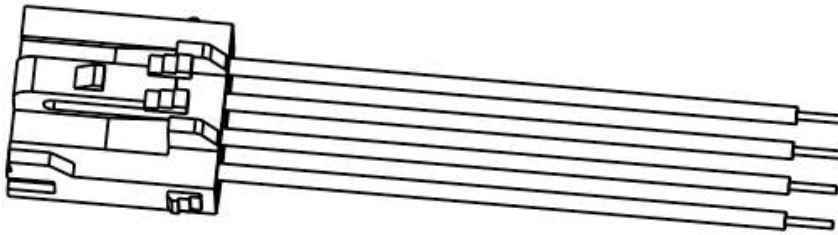

Schematic Diagram

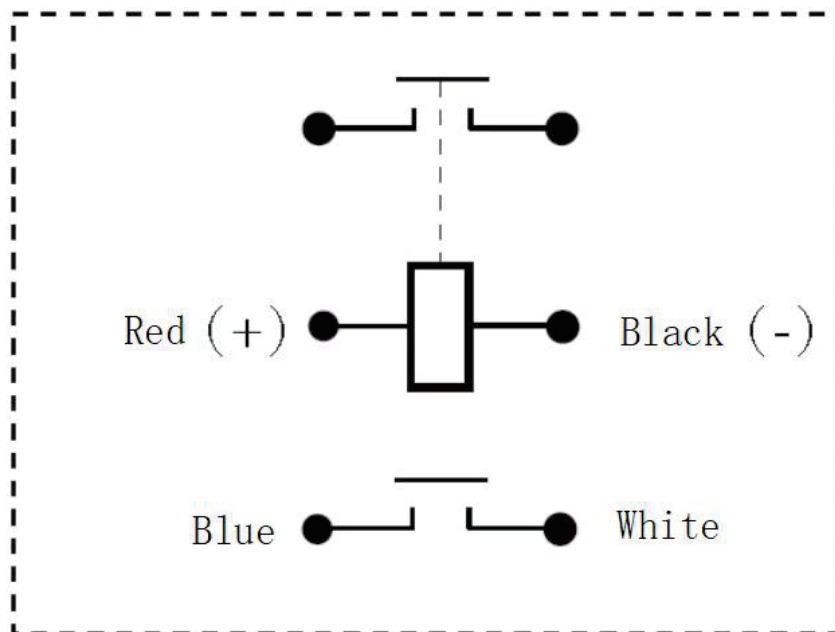

Note: No polarity at the load end, polarity at the coil end

NOTES:

● Mounting Precautions

1. By principle, please do not use it when the relay drops on the ground.

2. It's forbidden use the product at the temperature beyond $-40\text{ }^{\circ}\text{C} \sim 85\text{ }^{\circ}\text{C}$ for a long time as the relay contacts are sealed and filled with gas and when the contact temperature changes, the gas will break the ceramic sealed chamber .

3. When installing the relay, always use washers to prevent the screws from loosening.

4. Tighten each screw with given torque as suggested. Exceeding the maximum torque may result in screw loose, breakage, etc. When using screws, please make sure the washers are strong enough to prevent the case from deformation.

5. Avoid mounting the relay near strong magnetic fields or a heat generator .

● Precautions for connection of the load terminals

1. Please avoid excessive load applied to the product. If the product exceeds the rated range, the performance of the product cannot be guaranteed.

2. Please treat the relay as a product with limited life and replace it when necessary.

3. Be careful that foreign particles or oil attach on the terminals, which will lead to abnormal heating on terminals. And below connectors or conductors with sizes are suggested.

10A	Min. 2mm^2 nominal cross-sectional area
20A	Min. 3mm^2 nominal cross-sectional area
40A	Min. 10mm^2 nominal cross-sectional area
60A	Min. 15mm^2 nominal cross-sectional area
100A	Min. 35mm^2 nominal cross-sectional area
150A	Min. 45mm^2 nominal cross-sectional area
200A	Min. 60mm^2 nominal cross-sectional area
250A	Min. 80mm^2 nominal cross-sectional area
300A	Min. 100mm^2 nominal cross-sectional area
400A	Min. 200mm^2 nominal cross-sectional area

●Coil Attention

- 1.Please note that when using a diode, the switching speed may decrease and cause a reduction in cut-off performance, we recommend installing a surge protector varistor.
- 2.The pick-up voltage and drop-out voltage will change with ambient temperature, please use rated voltage to make sure the relay operate reliable. Don't exceed maximum coil voltage.
- 3.Please do not continuously load the maximum voltage on the coil.
- 4.For products with energy-saving plates, it is recommended to use a fast rise (step power supply method) for coil drive.
- 5.For products with energy-saving boards, the coil current will be automatically switched after 0.1s, please do not switch the coil voltage repeatedly within <0.1s, otherwise the product performance cannot be guaranteed.

Disclaimer:

We could not evaluate all the performance and parameters for every possible application. Thus the users should be in a right position to choose the suitable product for their own application. If there is any query, please contact Sanyou for technical service. However it is the users' responsibility to determine which product should be used only.

SANYOU CORPORATION LIMITED. All rights reserved by Sanyou.