



## Photo Voltaic Relay

## SLE

**Features**

- Miniature relay with high switching capability : 35A.
- Contact form : Form A , contact Gap > 1.8mm.
- 4000VAC dielectric strength high and 6000V surge voltage (1.2/50  $\mu$ S) between coil and contact.
- product in accordance to IEC60335-1 and PTI $\geq$ 325.
- The appliance is able to meet VDE V 0126-1-1.
- 85°C compliant product is available.

**Safety certificate**

UL、cUL ( File No. ): E190598

VDE ( File No. ): 40036707

CQC ( File No. ):

CQC02001002109、CQC10002050461、CQC21002306488

**Contact Data**

Type	SLE-DM
Rated load ( Resistive load )	35A 277VAC
Max. switching current	40A
Max. switching voltage	277VAC
Max. switching power	9,695VA

**Characteristics**

Contact material	Silver alloy	
Contact resistance	100m $\Omega$ Max. (1A 6VDC)	
Operate time (at rated coil voltage)	18ms Max. (No diode)	
Release time	15ms Max. (No diode)	
Insulation resistance	Min. 1,000M $\Omega$ (at 500VDC)	
Dielectric strength	Between open contacts :	2,500VAC , 50/60Hz for 1min.
	Between coil and contact:	4,000VAC , 50/60Hz for 1min.
Vibration resistance	Destructive	10 ~ 55Hz, at double amplitude of 1.5mm.
	Function	10 ~ 55Hz, at double amplitude of 1.5mm.
Shock resistance	Destructive	100G Min.
	Function	10G Min.
Endurance	Mechanical endurance(at 7,200 ops./h)	5,000,000 cycles(at room temperature)
	Electrical endurance(at 360 ops./h)	30,000 cycles(the ventilation hole open) at room temperature
Ambient temperature	-40°C ~ +65°C ( No condensation )	

	For ambient temperature is 85°C, please contact Sanyou
Weight	Approx.30.0g

### Coil Data (at 20°C)

Nominal voltage (VDC)	Nominal operating current $\pm 10\%$ (mA)	Coil resistance $\pm 10\%$ ( $\Omega$ )	Max. allowable voltage	Operate voltage (Max.)	Release voltage (Min.)	Nominal operating power
5	450	11.1	130% of nominal voltage	75% of nominal voltage	5% of nominal voltage	2.25W
6	375	16				
9	250	36				
12	187.5	64				
24	93.75	256				

The data shown above are initial values. Do not apply maximum allowable voltage on coil for more than 10 minutes to avoid overheating of the coil.

### Safety Certificate Ratings (More details of approved ratings, please refer to the safety certificates)

Certificates	CQC	UL/CUL	VDE
File No	CQC02001002109 CQC10002050461 CQC21002306488	E190598	40036707
Approved ratings	35A 125/250/277VAC	35A 125/250/277VAC Resistive	35A 125/250/277VAC Resistive 35A 125/250/277VAC COS $\Phi$ =0.8

- (1) All values unspecified are at room temperature
- (2) Only typical ratings are listed above and the endurance differ in each load. Other specific load information are available upon request.
- (3) For sealed type testing, please open the ventilation hole in the case before test.

## Ordering Information

### Nomenclature

SLE	-S	-1	12	D	M	1	-F	-XX	Special Parameter : Nil-Standard type, Letter or number- Special requirement
									Insulation System : Nil-Standard , F - Class F , H - Class H
									Contact material : Nil-AgSnO <sub>2</sub> , 1-AgNi
									Contact Form : M - Form A
									Coil Power : D-2.25W
									Rated Coil Voltage(VDC) : 05 , 06 , 09 , 12 , 24
									Number of poles : 1-1 Pole
									Protective Construction : S-Flux proofed , SH-Sealed type washable
									Type : SLE

- ( 1 ) Flux-proof relays can not be used in the environment with pollutants like H<sub>2</sub>S, SO<sub>2</sub>,NO<sub>2</sub>, dust, etc.
- ( 2 ) Water cleaning or surface process is not suggested after the flux-proof relays are assembled on PCB.
- ( 3 ) Customized special suffix is available after being evaluated by Sanyou

## Outline dimension, wiring diagram, PCB layout (Unit: mm)

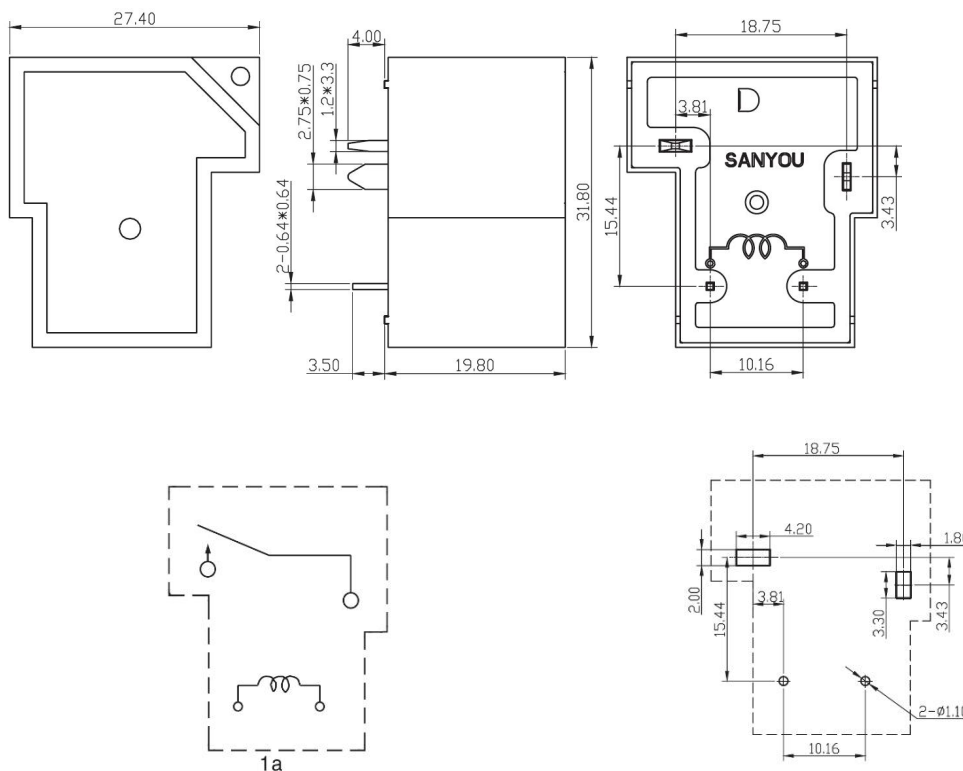

In case of no tolerance shown on outline dimension

If dimension < 1 mm, tolerance : ±0.2mm

If dimension 1~5mm, tolerance : ±0.3mm

If dimension > 5mm, tolerance : ±0.4mm

Note :

1. The dimension of pin is the size before tinning

2.Tolerance of PCB layout : ±0.1 mm.

Wiring Diagram ( bottom view )

PC.B Layout ( bottom view )

## Typical Applications

- Photovoltaic controller
- Charging pile
- New energy automobile

## Characteristic Curves

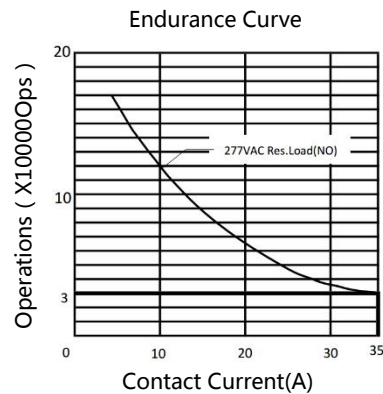
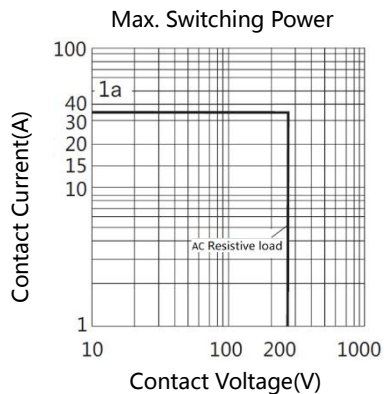

Note :

- (1) Test conditions: room temperature, flux-proof product, resistive load, 1s on, 9s off.
- (2) The above curves are for reference only, and the final result is subject to the experiment.

Note :

If you choose the sealed type, before using, please remove the convex platform at the top of the case to ensure the normal performance of the relay after the completion of a PCB operations. they are as shown in the following diagram :

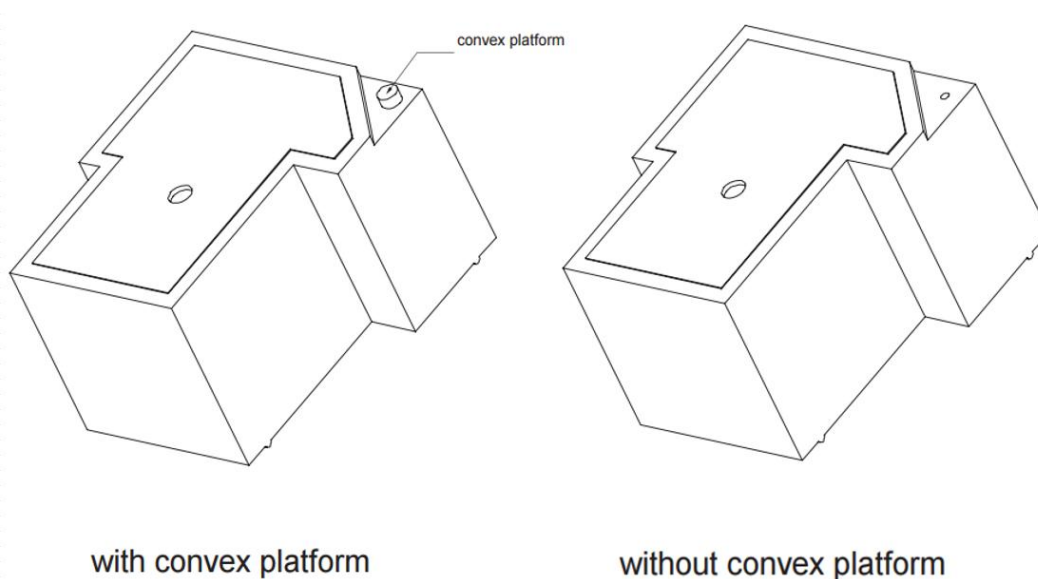

Disclaimer:

This datasheet is the customers' reference. All the specification are subject to change without notice. We could not evaluate all the performance and all the parameters for every possible application. Thus the user should in a right position to choose the suitable product for their own application. For sealed relays after installation and cleaning, please open the vent hole on the case before use. If there is any query, please contact Sanyou for the technical service. However it is the user's responsibility to determine which product should be used.