

产品特点 Product feature

- 新能源汽车预充继电器
New energy vehicle precharge relay
- 额定40A触点切换能力
Rated 40A contact switching capability
- 普通安装以及3种凸缘安装可供选择
Normal mounting and 3 flange mounting options are available
- 环保产品，符合RoHS要求
Environmental protection products, meet RoHS requirements

触点参数

Contact Data

触点形式 Arrangement	一组常开触点 1 Form A
额定负载电流 Rated load current	40A
接触电阻 contact resistance	$\leq 5\text{m}\Omega$ (at 1A)
最大切换电压 Maximum switching voltage	850VDC (at 2A)
最大分断电流 Maximum breaking current	50A (450VDC) 5times
最大切换功率 Maximum switching power	22.5KW
电耐久性 (1) The durability of electricity	容性负载 Capacitive load Making 1×10^3 (750VDC, $\tau = 1\text{ms}$, impact 200A steady state 40A)
	阻性负载 Impedance load Switching: 3×10^3 , (40A, 450VDC) Making: 1×10^5 , (40A, 450VDC)

性能参数

Parameter Data

机械耐久性 Mechanical durability	5×10^5 Times	
绝缘电阻 Insulation resistance	1000M Ω (500VDC)	
介质 耐压 Medium pressure	触点间 Contact between	2500VAC 1min 10mA
	触点与线圈 Contacts and coils	2500VAC 1min 10mA
动作时间(额定电压下) Actuation time (at rated voltage)	$\leq 30\text{ms}$	
释放时间(额定电压下) Releasing time (at rated voltage)	$\leq 10\text{ms}$	
冲击 Shock	稳定性 Functional	196m/s ² (20G)
	强度 Destructive	490m/s ² (50G)
振动 Vibration	10Hz~500Hz 49m/s ² (5G)	
工作环境温度 Operating ambient temperature	-40°C~85°C	
工作环境湿度 Working environment humidity	5%~85% RH	
重量 Weight	Approx 50 g	
长×宽×高 (mm) Length × width × height (mm)	30.1×44×30	

载流能力 ⁽²⁾ current-carrying capability	40A: continuous
	60A: 1h
	80A: 20min
	160A: 30s
	240A: 10s
	400A: 0.6s

线圈参数⁽³⁾

Coil Data

额定电压 (VDC) Rated voltage (VDC)	12	24	48
最大工作电压 (VDC) Maximum operating voltage (VDC)	18	36	72
吸合电压 (VDC) Suction voltage (VDC)	≤7.2	≤14.4	≤28.8
释放电压 (VDC) Release voltage (VDC)	≥1.2	≥2.4	≥4.8
线圈电阻 (Ω) ±10% Release voltage (VDC)	55.4	222	886
线圈功率 (W) Coil power (W)	2.6	2.6	2.6

备注:

- (1) 除特别标明外, 电耐久性测试环境温度均为 23°C, 通断比(on:off) 为0.6s: 5.4s。
- (2) 环境温度为23°C, 导线截面积≥10mm²。
- (3) 如需其他额定电压, 可特殊订货。

Remarks:

- (1) Unless otherwise indicated, the ambient temperature of the electrical durability test is 23°C, and the on-off ratio is 0.6s: 5.4s
- (2) The ambient temperature is 23°C, and the traverse area is ≥10mm².
- (3) If other rated voltage is required, special order can be made.

订货标记
Order tag

型号命名规则 Model naming rules	
SEF40- □ - M □ □ □ □	
客户特性号 Customer Feature Number	无 : 无客户特殊要求 None: There is no special requirement
数字或字母 Numbers or letters	客户特殊要求, 与结构无关 customer specific requirements, independent of structure
安装方式 Way to install	无 : 普通安装、 G, G2, G3 : 凸缘安装 None: Common installation. G, G2, G3: flange installation
端子形式 Terminal form	无 : 快接端子 None: Fast access terminal P : PCB端子 P: PCB
线圈电压 The coil voltage	12 : 12VDC、 24 : 24VDC
触点组数 Contact group	M : 1组常开触点 M: 1 set of normally open contacts
封装类型 Encapsulated type	S : 塑封型 S: Plastic seal
基本型号 The basic model	SEF40

外形尺寸 (快插型)
Overall size (quick plug type)

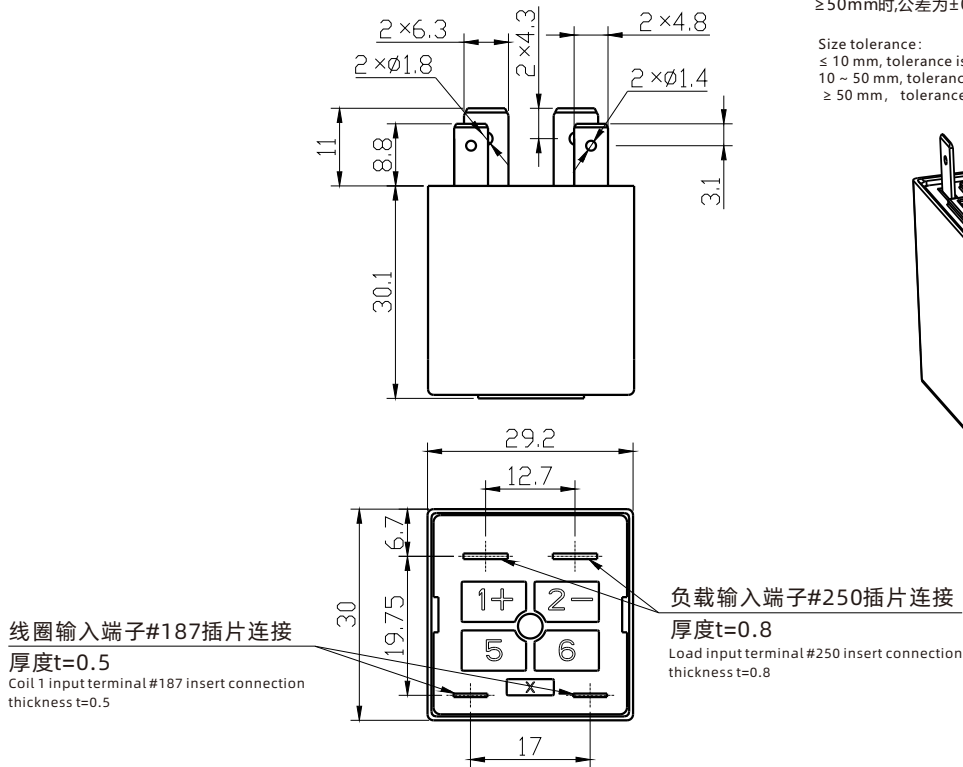

尺寸公差:
≤10mm时,公差为±0.3mm
10~50mm时,公差为±0.5mm
≥50mm时,公差为±0.8mm

Size tolerance:
≤ 10 mm, tolerance is ±0.3 mm
10 ~ 50 mm, tolerance is ±0.5 mm
≥ 50 mm, tolerance is ±0.8 mm

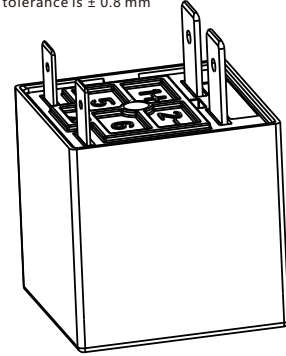

外形尺寸 (PCB型)
Overall size (PCB)

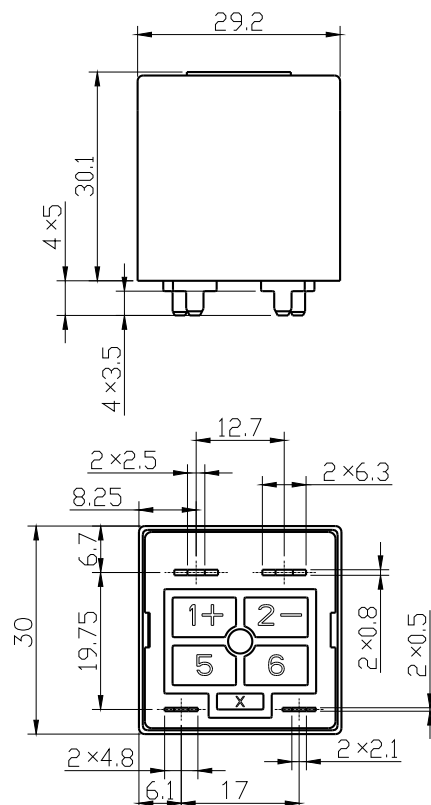

尺寸公差:
≤10mm时,公差为±0.3mm
10~50mm时,公差为±0.5mm
≥50mm时,公差为±0.8mm

Size tolerance:
≤ 10 mm, tolerance is ±0.3 mm
10 ~ 50 mm, tolerance is ±0.5 mm
≥ 50 mm, tolerance is ±0.8 mm

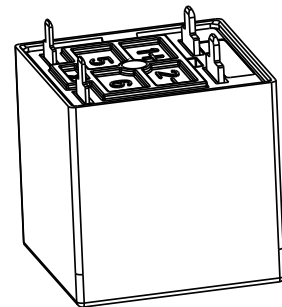

外形尺寸 (G型)
Overall size (TYPE G)

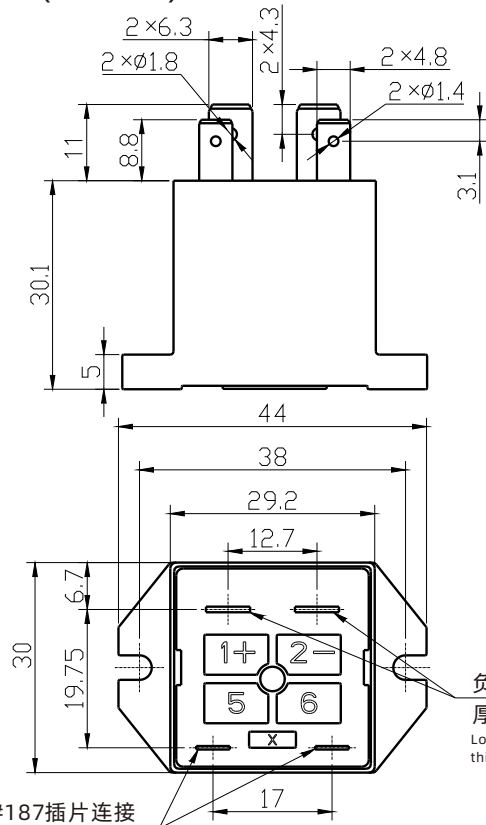

线圈输入端子#187插片连接
厚度t=0.5
Coil 1 input terminal #187 insert connection
thickness t=0.5

尺寸公差:
≤10mm时,公差为±0.3mm
10~50mm时,公差为±0.5mm
≥50mm时,公差为±0.8mm

Size tolerance:
≤ 10 mm, tolerance is ±0.3 mm
10 ~ 50 mm, tolerance is ±0.5 mm
≥ 50 mm, tolerance is ±0.8 mm

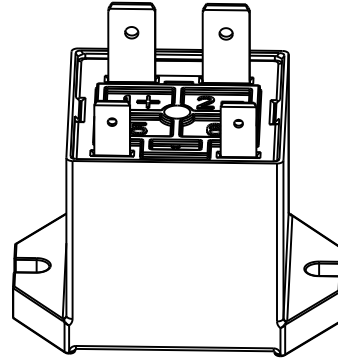

负载输入端子#250插片连接
厚度t=0.8
Load input terminal #250 insert connection
thickness t=0.8

外形尺寸 (G2型)
Overall size (TYPE G2)

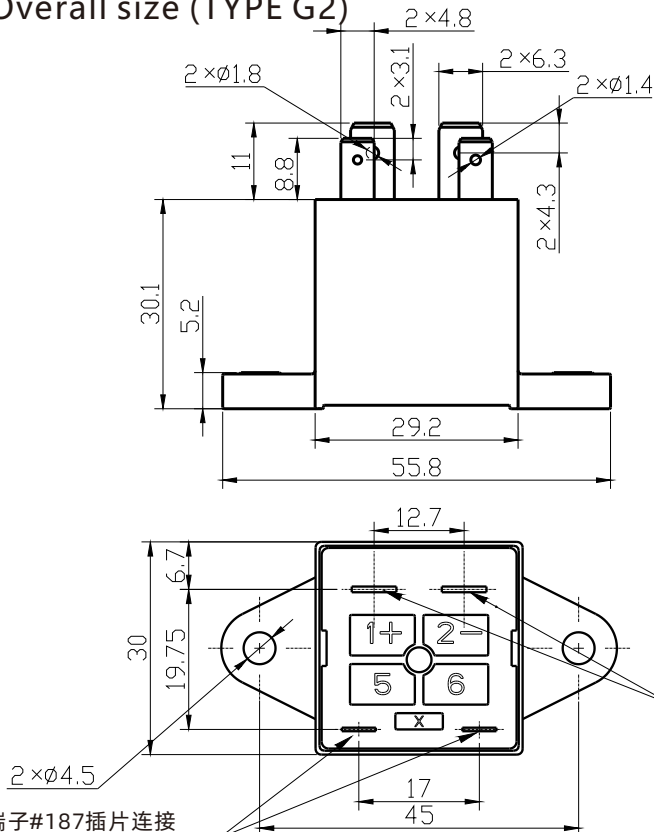

线圈输入端子#187插片连接
厚度t=0.5
Coil 1 input terminal #187 insert connection
thickness t=0.5

尺寸公差:
≤10mm时,公差为±0.3mm
10~50mm时,公差为±0.5mm
≥50mm时,公差为±0.8mm

Size tolerance:
≤ 10 mm, tolerance is ±0.3 mm
10 ~ 50 mm, tolerance is ±0.5 mm
≥ 50 mm, tolerance is ±0.8 mm

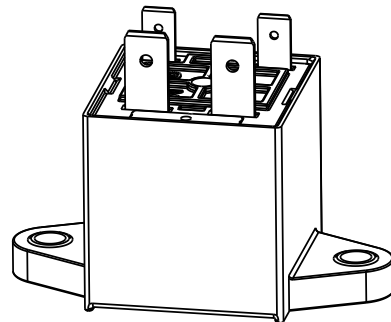

负载输入端子#250插片连接
厚度t=0.8
Load input terminal #250 insert connection
thickness t=0.8

外形尺寸 (G3型)
Overall size (TYPE G3)

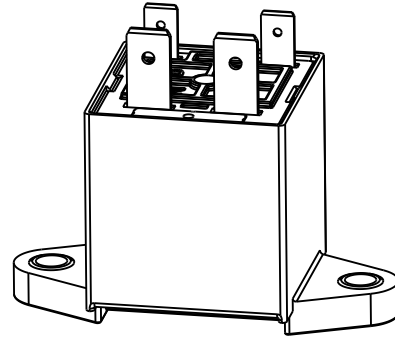
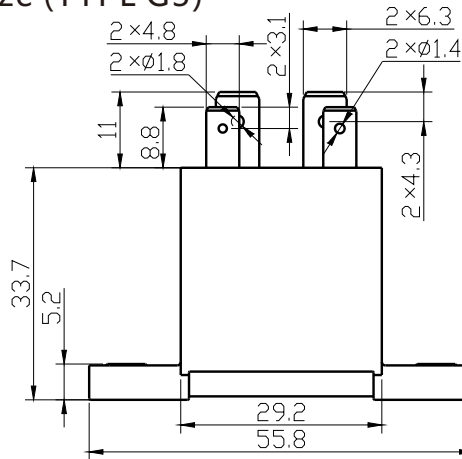

尺寸公差
≤10mm时,公差为±0.3mm
10~50mm时,公差为±0.5mm
≥50mm时,公差为±0.8mm

Size tolerance:
≤ 10 mm, tolerance is ±0.3 mm
10 ~ 50 mm, tolerance is ±0.5 mm
≥ 50 mm, tolerance is ±0.8 mm

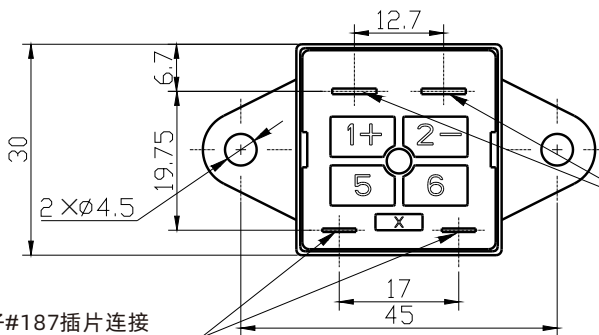

负载输入端子#250插片连接

厚度t=0.8

Load input terminal #250 insert connection
thickness t=0.8

线圈输入端子#187插片连接

厚度t=0.5

Coil 1 input terminal #187 insert connection
thickness t=0.5

安装尺寸
Mounting dimension

原理图
Schematic diagram

G型安装尺寸
G mounting dimensions

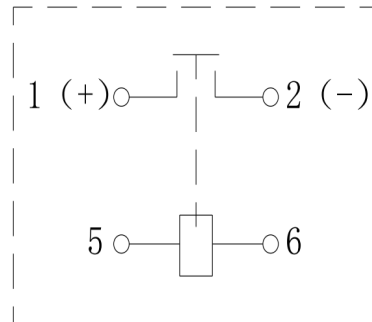

G2型, G3型安装尺寸
G2, G3 mounting dimensions

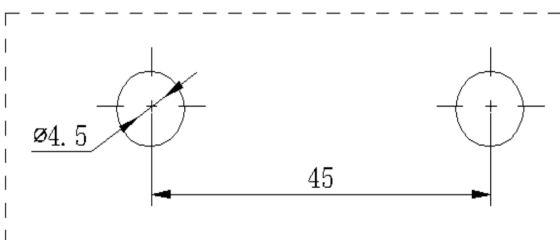

性能曲线图 Characteristic Curves

Terminal temperature rise curve
 Test items:SEF40-450M12G(2.6W)
 Amount:3PCS
 Coil voltage:12VDC
 Load current:40A,60A,80A
 Environment temperature:23°C

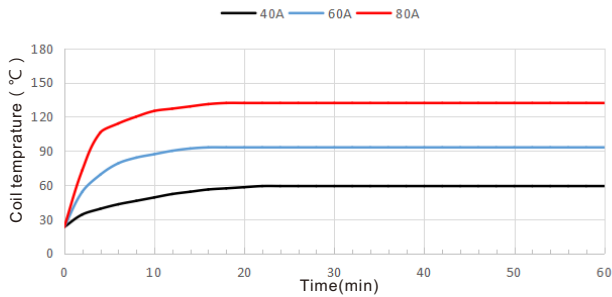

Terminal temperature rise curve
 Test items:SEF40-450M12G(2.6W)
 Amount:3PCS
 Coil voltage:12VDC
 Load current:40A,60A,80A
 Environment temperature:85°C

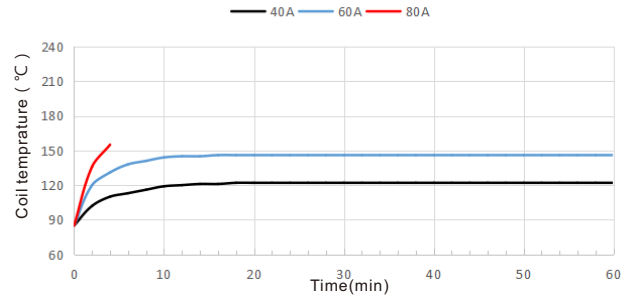

说明:

●继电器安装注意事项

- 1.在安装继电器时，一定要使用垫圈以防止螺丝松动；
- 2.在安装继电器时，锁紧继电器负载端扭力矩与安装孔扭力矩请控制在建议范围内，在超过范围的情况下，可能会造成端子滑牙或外壳破损，使用螺钉时，确保垫圈强度足够，否则会变形撑坏外壳；
- 3.在安装继电器时，请不要靠近强磁场和发热源。

Description:

● Precautions for relay installation

1. When installing the relay, make sure to use washers to prevent screw loosening;
2. When installing the relay, the torsional torque of the load end of the locking relay and the torsional torque of the mounting hole should be controlled within the recommended range. If the torsional torque exceeds the recommended range, the terminal sliding teeth or the shell may be damaged.
3. Keep away from the strong magnetic field and heat source when installing the relay.

●继电器负载端连接注意事项

1. 请避免过度负载应用到产品上，如果超出额定范围，产品的性能无法保证；
2. 请将继电器看做是有截止寿命的产品，不要超过开关的容量和使用寿命，为确保安全，应及时替换；
3. 继电器的负载端子是有极性的，请按产品外表标示极性要求连接负载，否则产品性能无法保证；
4. 小心异物或油粘着在负载端子部分，这样可能导致负载端子散热异常，同时请使用以下标称截面积的连接导线或铜排。

● Matters needing attention in connection of relay load end

1. Please avoid excessive load applied to the product. If it exceeds the rated range, the performance of the product cannot be guaranteed;
2. Please regard the relay as a product with cut-off life and do not exceed the capacity and service life of the switch. To ensure safety, it should be replaced in time;
3. The load terminal of the relay is polar, please connect the load according to the polarity requirements marked on the appearance of the product, otherwise the product performance cannot be guaranteed;
4. If foreign matter or oil is stuck to the load terminal, heat dissipation of the load terminal may be abnormal. Use the following wire or copper bar with nominal cross-sectional area.

10A	公称截面积 (Nominal cross-sectional area)	$\geq 2\text{mm}^2$
20A	公称截面积 (Nominal cross-sectional area)	$\geq 3\text{mm}^2$
40A	公称截面积 (Nominal cross-sectional area)	$\geq 10\text{mm}^2$
60A	公称截面积 (Nominal cross-sectional area)	$\geq 15\text{mm}^2$
100A	公称截面积 (Nominal cross-sectional area)	$\geq 35\text{mm}^2$
150A	公称截面积 (Nominal cross-sectional area)	$\geq 45\text{mm}^2$
250A	公称截面积 (Nominal cross-sectional area)	$\geq 80\text{mm}^2$
300A	公称截面积 (Nominal cross-sectional area)	$\geq 100\text{mm}^2$

●继电器线圈端连接注意事项

- 1.使用二极管吸收线圈反向电压时，会导致继电器释放时间延长，继电器负载切换性能下降，推荐使用可变电阻方式；
- 2.在继电器使用时，考虑到使用环境温度和条件，继电器动作及释放电压将会变化，推荐使用额定电压给线圈供电以保证继电器正常工作；
- 3.请勿持续在线圈上加载最大电压；
- 4.带节能板的产品（200A及200A以上产品），推荐使用快速上升（阶跃供电方式）进行线圈驱动；
- 5.带节能板的产品（200A及200A以上产品），在0.1s后产品进行线圈电流的自动切换，请不要在 < 0.1s内重复切换线圈电压，否则产品性能不能保证。

● Matters needing attention in connection of relay coil end

1. When the diode absorbs the reverse voltage of the coil, the release time of the relay will be prolonged and the load switching performance of the relay will decline. Therefore, variable resistance is recommended.
2. When the relay is in use, considering the ambient temperature and conditions, the action and release voltage of the relay will change, it is recommended to use the rated voltage to supply power to the coil to ensure the normal operation of the relay;
3. Do not continuously load the maximum voltage on the coil;
4. For products with energy-saving board (200A and above), it is recommended to use fast rise (step power supply mode) for coil drive;
5. For products with energy-saving board (200A and above), coil current will be automatically switched after 0.1s. Please do not switch coil voltage repeatedly within 0.1s, otherwise the product performance cannot be guaranteed.

声明:

本产品规格书仅供客户使用时参考，若有更改，恕不另行通知。

对三友而言，不可能评定继电器在每个具体应用领域的所有性能要求，因而客户应该根据具体的使用条件选择与之相匹配的产品，若有疑问，请与三友联系获取更多的技术支持，但产品选型责任仅由客户负责。

Statement:

This product specification is for reference only, subject to change without prior notice. For Sanyou, it is impossible to assess all the performance requirements of relays in each specific application field, so customers should choose the products that match them according to the specific use conditions. If in doubt, please contact Sanyou for more technical support, but the responsibility of product selection is solely the customer's responsibility.