

Features

特点

- Rated 250A contact switching capacity
额定250A切换
- Not position sensitive- can be mounted in any position ,easy to be installed.
非位置敏感型-可安装在任意位置,用于易于安装
- It can be adjusted to abnormal operating conditions and switched to 10-times over-current
能满足非正常工况要求,以及10倍额定电流切换

Contacts Data

触点参数

Contact arrangement 触点形式	Power Contact:1 Form A 一组常开触点	
Rated load current 额定负载电流	250A	
Contact resistance 接触电阻	≤0.3mΩ (@10A)	
Max. Switching voltage 最大切换电压	14VDC	
Electrica endurance 电寿命 (1)	Load current	Switching times
	10A	≥150K
	60A	≥100K
Breaking current 分断能力	250A	≥10K
	1200A	≥20
	2000A	≥6
	Load current capacity ⁽²⁾ 电流承载能力 ⁽²⁾	Load current
200A		40000sec
250A		18000sec
400A		370sec
600A		150sec
1000A		12sec
2000A		1sec
4000A		0.15sec
5000A	0.1sec	

Parameters Date

性能参数表

Mechanical life 机械耐久性	5×10 ⁵ times	
Insulation resistance 绝缘电阻	1MΩ(500VDC)	
Dielectric strength 介质耐压	Between open contacts 触点间	1000VAC 1min. 10mA
	Between contact and coil 触点与线圈	1000VAC 1min. 10mA
Operate time (at rated coil voltage) 动作时间 (额定电压下)	≤15ms	
Reset time (at rated coil voltage) 复归时间 (额定电压下)	≤10ms	
Shock resistance 冲击	Functional 耐久	100GMin
	Destructive 误动作	50GMin
Ambient temperature 工作环境温度	-40℃~105℃	
Ambient humidity 工作环境湿度	5%~95% RH	
Weight 重量	110g±10g	
Noise 噪音	60dB (50cm)	
Protection level 防护等级	IP64	

NOTES:

备注:

(1) The electrical endurance test temperature is 65°C, whilst break-make ratio 0.6s:5.4s unless marked otherwise

除特别标明外,电耐久性测试环境温度均为65°C,通断比 (on:off) 为0.6s:5.4s

(2) Maximum continuous current, ambient temperature is 85°C,

wire cross-sectional area 50mm²

最大持续电流,环境温度为85°C,导线横截面积50mm²

Coil Data (at 23°C)

线圈参数

Rated voltage 额定电压 (VDC)	Rated current 额定电流 ±10% (A)	Coil resistance 线圈电阻 ±10% (Ω)	Pick-up voltage 线圈工作电压 (Max.VDC)	Pulse 脉冲 (ms)	Rated power 额定功率
12	3	2x4	4~24v	100~300	36W
24	1.5	2x16	8~36v	100~300	36W

Ordering Information
订货标记

Model naming rules 型号命名规则			
SY200	S-1	24	D M
Contact form: M—SPST 触点形式: M-单刀单掷			
Coil Power: D-36W 线圈功率: D-36W			
Coil Voltage(VDV) : 12/24VDC 线圈规格 (VDC) : 12/24			
Number of contact groups: 1-1 group 触点组数: 1-1组			
Packaging form: s-plastic encapsulated 封装形式: S-塑封式			
Type Designation SY200 基本型号: SY200			

Outline Dimensions
正常品外形尺寸

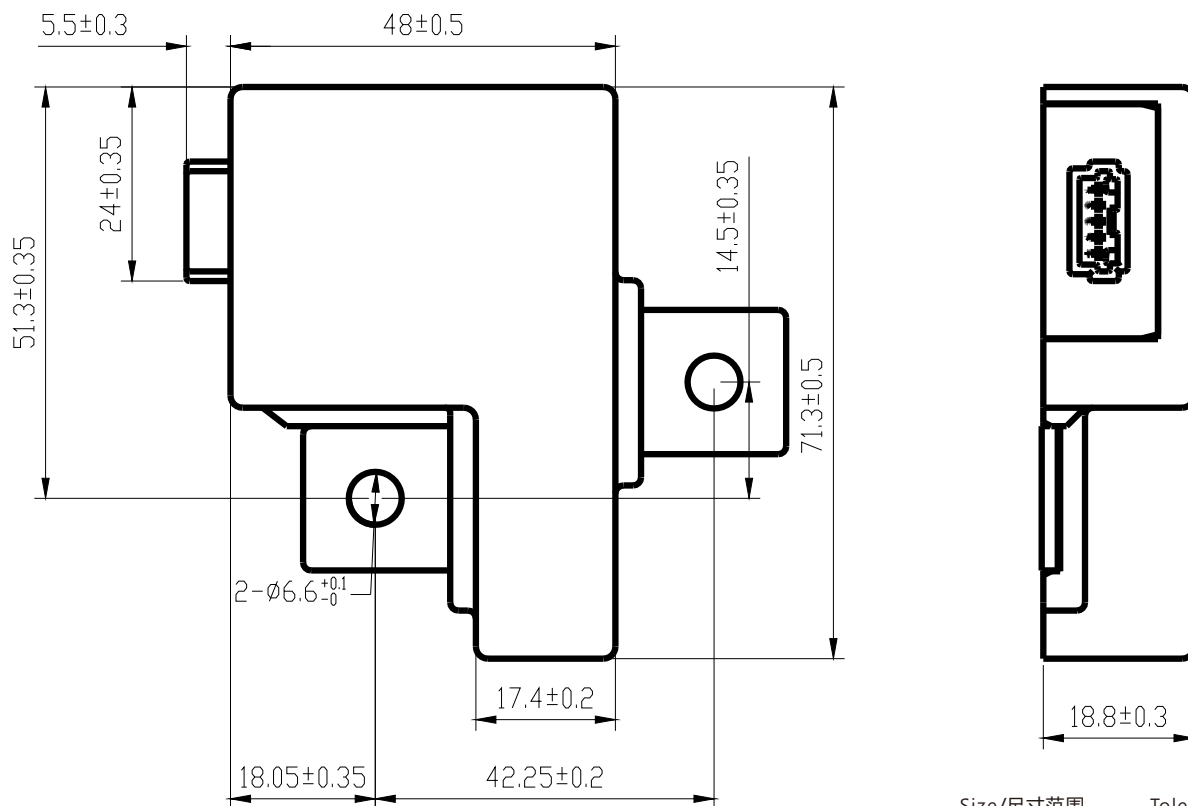

Size/尺寸范围	Tolerance/公差
≤10mm	±0.3
10mm~50mm	±0.5
≥50mm	±0.8

Mounting dimensions 安装尺寸

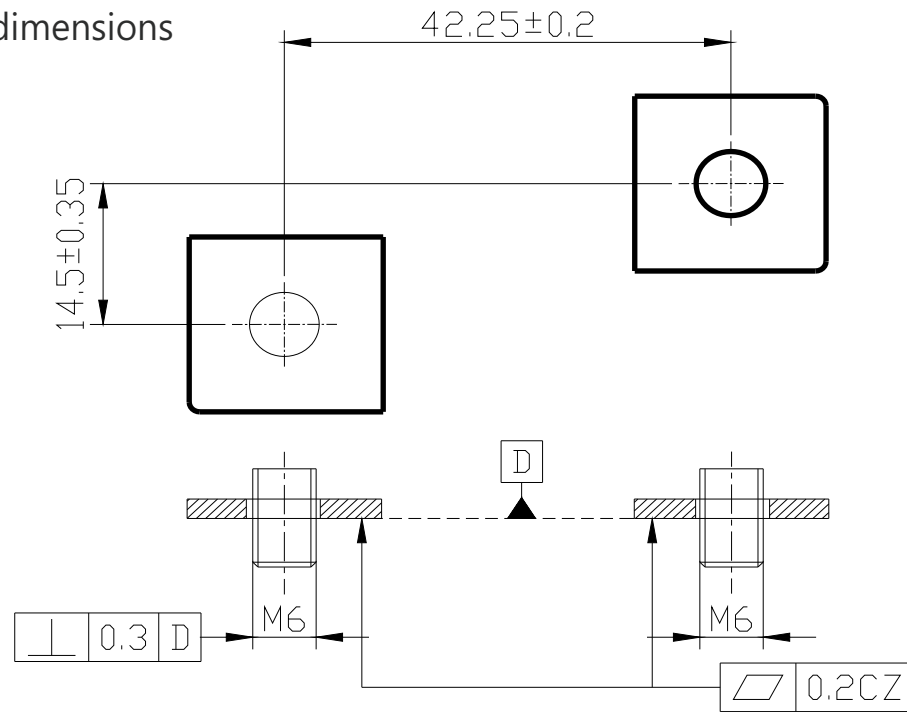

Max, tightening torque: 13.2 Nm

Schematic diagram of low voltage apparatus 低压电气原理图

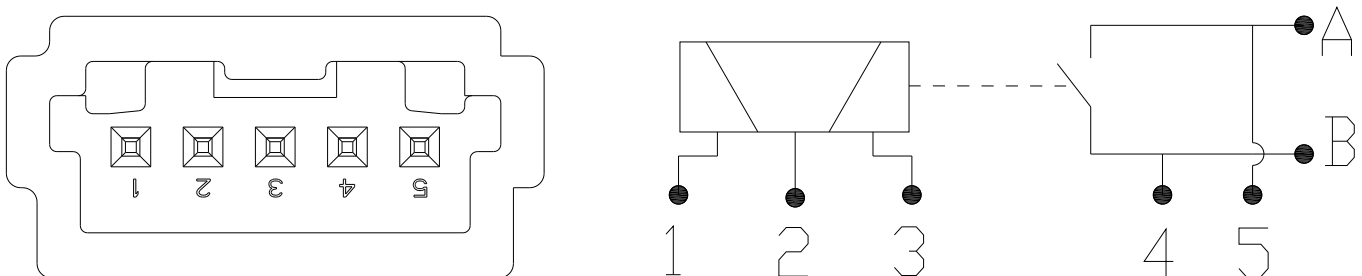

Definition of low voltage interface 低压接口定义

Pin 引脚	Function 功能
1	Reset coil (-) 复位线圈 (-)
2	Common end of action and reset coil 动作和复位线圈的公共端 (+)
3	Reset coil (-) 动作线圈 (-)
4	Signal output of load pin A 负载引脚A的信号输出
5	Signal output of load pin B 负载引脚B的信号输出
A	Load pin A 负载引脚A
B	Load pin B 负载引脚B

Low voltage communication interface

低压通讯接口

Plug type: 5pin Connector

插口类型 5pin连接器

Molex type: 502351-0501

Molex零件号:

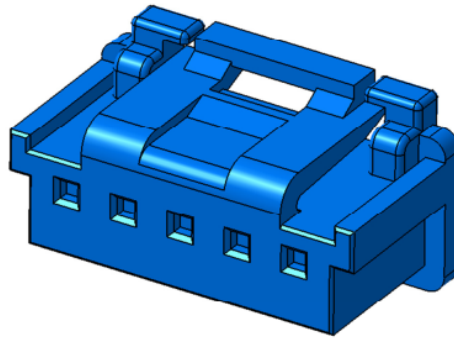

Low voltage communication interface (plug)

低压通讯接口 (插头)

Mating end connector: 502352-0501

对配端连接器:

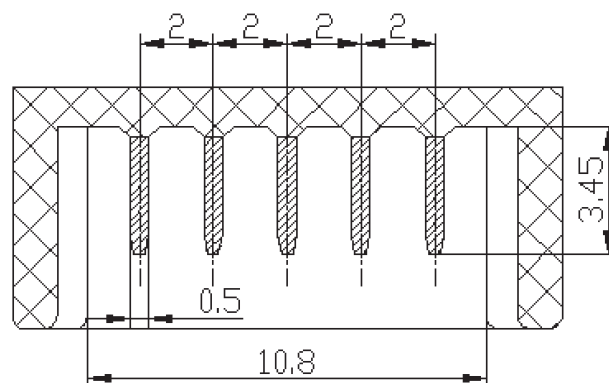
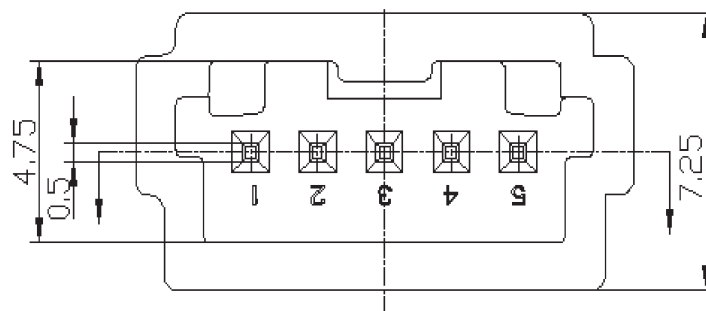

Low voltage communication interface (socket)

低压通讯接口 (插座)

NOTES**说明****●Mounting Attention/继电器安装注意事项**

1. When installing the relay, always use washers to prevent the screws from loosening.
 2. Tighten each screw within the rated range given in the outline dimensions. Exceeding the maximum torque may result in breakage.
 3. Avoid mounting the relay in strong magnetic fields (near a transformer or magnet) or close to an object that radiates heat.
1. 在安装继电器时，一定要安装垫圈，防止螺钉松动。
 2. 用螺钉锁紧继电器负载端时请控制在外形尺寸范围内。超过最大扭矩可能导致外壳破损。
 3. 安装继电器时，请不要靠近强磁场（变压器或磁铁附近）和发热源。

●Electrical Life Attention/继电器负载端连接注意事项

1. This relay is a DC high-voltage switch. In its final breakdown mode, it may lose the ability to provide the proper cut-off. Therefore, do not exceed the indicated switching capacity and life.
 2. Please treat the relay as a product with limited life and replace it when necessary.
 3. The contacts of the relay are polarized. Please follow instructions in the connection schematic when connecting the contacts.
 4. Be careful that foreign matter and oils and fats kind, don't stick to the main terminal parts because it is likely to cause terminal parts to give off unusual heat. Also, please use the following specifications of conductor.
1. 此产品为高压直流继电器。在发生故障时，可能会失去应有的分断能力。因此，不要超过继电器的功率和寿命。
 2. 请将继电器视为有寿命的电气产品，必要的时候需要更换。
 3. 继电器的是有极性的。请按照连接示意图中的说明接线。
 4. 小心异物或油粘在负载端子部分，这样可能导致负载端子散热异常，同时请按下表公称面积的连接导线或铜排。

10A	Min. 2mm ² nominal cross-sectional area	最小2mm ² 公称面积
20A	Min. 3mm ² nominal cross-sectional area	最小3mm ² 公称面积
40A	Min. 10mm ² nominal cross-sectional area	最小10mm ² 公称面积
60A	Min. 15mm ² nominal cross-sectional area	最小15mm ² 公称面积
100A	Min. 35mm ² nominal cross-sectional area	最小35mm ² 公称面积
150A	Min. 45mm ² nominal cross-sectional area	最小45mm ² 公称面积
200A	Min. 60mm ² nominal cross-sectional area	最小60mm ² 公称面积
250A	Min. 80mm ² nominal cross-sectional area	最小80mm ² 公称面积
300A	Min. 100mm ² nominal cross-sectional area	最小100mm ² 公称面积
350A	Min. 120mm ² nominal cross-sectional area	最小120mm ² 公称面积

●Coil Attention/线圈端连接注意事项

- 1.Please note that when using a diode, the switching speed may decrease and cause a reduction in cut-off performance, we recommend installing a surge protector varistor.
- 2.The pick-up voltage and drop-out voltage will change with ambient temperature, please use rated voltage to make sure the relay operate reliable. Don't exceed maximum coil voltage.
- 3.The 250A and 300A types have built-in dedicated drive circuit, please drive the coil with a quick startup (Built-in one-shot pulse generator circuit).
- 4.After the ON signal enters the 250A and 300A types, automatic coil current switching occurs after approximately 0.1 seconds. Do not repeatedly turn it OFF within that 0.1seconds interval, as doing so may damage the relay.

- 1.请注意，当使用二极管时，继电器闭合和断开的速度可能会降低并导致分断能力下降，我们建议安装浪涌保护器压敏电阻。
- 2.吸合电压和释放电压会随着温度的变化而变化，请使用额定电压。不要超过线圈的最大电压。
- 3.250A和300A规格的产品内部设有专用的驱动电路，请快速启动线圈(内部设有一次性脉冲发生器电路)。
- 4.在ON信号进入250A和300A规格的产品后，线圈电流大约在0.1s后自动接通。不要在0.1秒的间隔内反复关闭它，因为这样做可能会损坏继电器。

Disclaimer:

This datasheet is the customers' reference. All the specification are subject to change without notice.

We could not evaluate all the performance and parameters for every possible application. Thus the users should be in a right position to choose the suitable product for their own application. If there is any query, please contact Sanyou for technical service. However it is the users' responsibility to determine which product should be used only.

© SANYOU CORPORATION LIMITED. All rights reserved by Sanyou.

声明:

本产品规格书仅提供客户使用时参考，若有更改，恕不另行通知。

对三友而言，不可能评定继电器在每个具体应用领域的所有性能参数要求，因而客户因该根据具体使用条件选择与之相匹配的产品，若有疑问，请与三友联系获取更多技术支持。但产品选型责任仅由客户负责。

© 三友联众集团股份有限公司版权所有，本公司保留所有权利。