



Feature

- 150 amps continuous carry, 1500 amps interrupte under extreme condition.
- Hermetically sealed with hydrogen gas, the arc is not exposed. Be able to use in explosive & harsh environments without oxidation or contamination of contacts. Contacts' part meet IP42 protection degree.
- Not position sensitive- can be mounted in any position for ease of installation.
- RoHS compliant.

Contact Data

Item	Information		
Contact arrangement	1 Form A contact		
Current rating	150A		
Contact resistance	≤0.5mΩ (@6V 20A)		
Min.Switching load	12VDC 1A		
Max. Switching voltage	750VDC		
Max. Breaking current	1200A (300VDC, 1 cycle)		
Max. Switching power	112.5KW		
Electrical life ⁽¹⁾	Resistive load	500V type	750V type
		500VDC,150A 1×10 ³ cycles	750VDC,150A 100 cycles
	Capacitive load	500VDC,-150A 500 cycles	750VDC,-150A 100 cycles
		2.5×10 ⁴ cycles 22.5VDC,τ=1ms inrush 400A steady 150A	1×10 ⁴ cycles 37.5VDC,τ=1ms inrush 400A steady 150A
Load current capacity ⁽²⁾	150A: continuity		
	180A: 2h		
	225A: 15min		
	320A: 2min		
	400A: 60S		
	600A: 20s		
	900A: 8s		

NOTES:

(1) Ambient temperature:23°C, L/R≤1ms.

(2) Ambient temperature:23°C, 35mm² conductor.

(3) Other types of rated voltage,please contact us.

Parameters Table

Item	Information	
Mechanical life	2×10 ⁵ cycles	
Insulation resistance	1000MΩ(500VDC)	
Dielectric strength	Between open contacts	3000VAC 1min 10mA
	Between contact and coil	4000VAC 1min 10mA
Operate time (at rated coil voltage)	≤30ms	
Release time (at rated coil voltage)	≤10ms	
Shock resistance	Functional	196m/s ² (20G)
	Destructive	490m/s ² (50G)
Vibration resistance	10Hz~500Hz 49m/s ² (5G)	
Ambient temperature	-40°C~85°C	
Ambient humidity	5%~85% RH	
Weight	Approx.300g	
External dimension	76mm×40mm×67mm	

Coil Data ⁽³⁾

Rated voltage (VDC)	12	24	48
Operation voltage (VDC)	12	24	48
Max. voltage (VDC)	16	32	64
Pick-up voltage (VDC)	≤9	≤18	≤36
Drop-out voltage (VDC)	≥1.0	≥2.0	≥4.0
Coil vesistance(±10%)(Ω)	26	104	419
Operating power (inrush, W)	5.5	5.5	5.5
Operating power (stable, W)	5.5	5.5	5.5

Ordering Information

Nomenclature	
SES 150D-	<input type="checkbox"/> M <input type="checkbox"/> <input type="checkbox"/> 2 <input type="checkbox"/> <input type="checkbox"/>
Customer special code Nil: No customer special requirement Numbers or Letters: Customer special requirement	
Reinforce the way 1: Card buckle type 2: Screw type	
Load connection type 2: internal thread	
Coil connection type Nil: outgoing line C: outgoing line+connector	
Coil voltage 12: 12VDC 24: 24VDC 48: 48VDC	
Contact arrangement M: 1 Form A	
Voltage rating 750: 12~750VDC 500: 12~500VDC	
Load current 150: 150A	
Type designation SES	

Packing quantity:1 pcs inner carton, 20pcs outer carton

Outline Dimensions(Card buckle type)

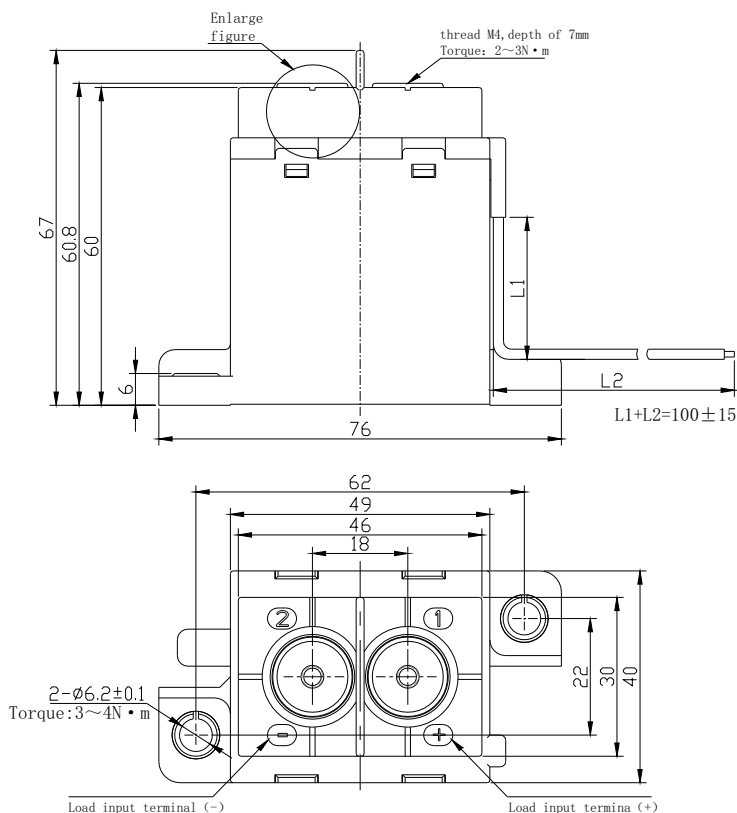

Enlarge figure

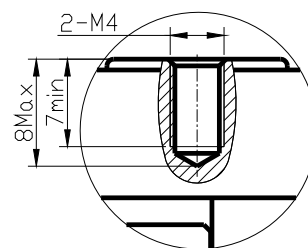

Size	tolerance
Less than 10mm:	±0.3
10 to 50mm:	±0.5
More than 50mm:	±0.8

Outline Dimensions(screw type)

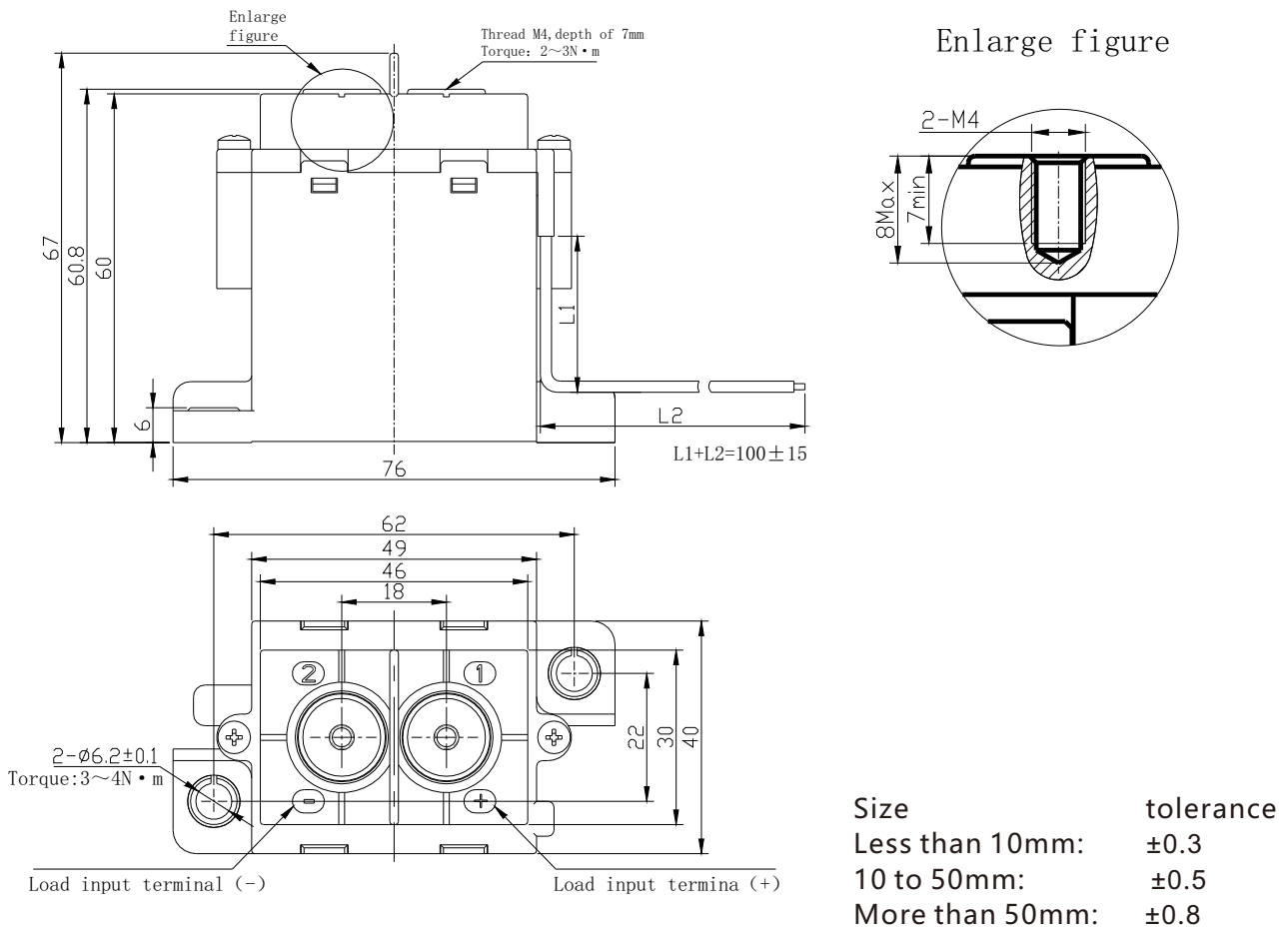

Coil Connection Type

C: Outgoing Line+Connector (Accessories)

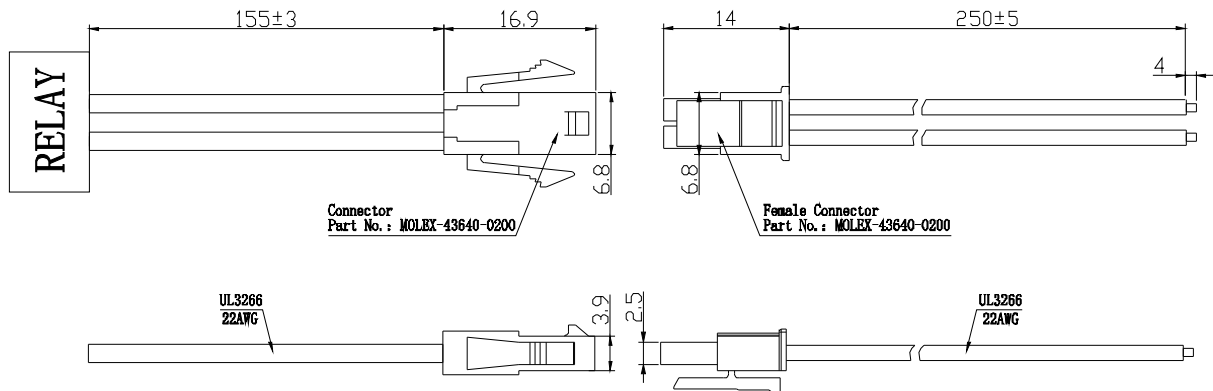

Installation Size Chart

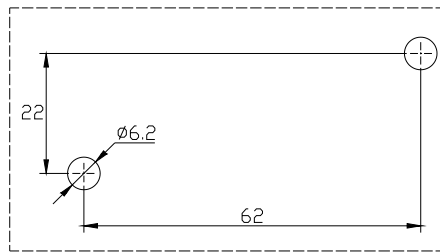

Schematic Diagram

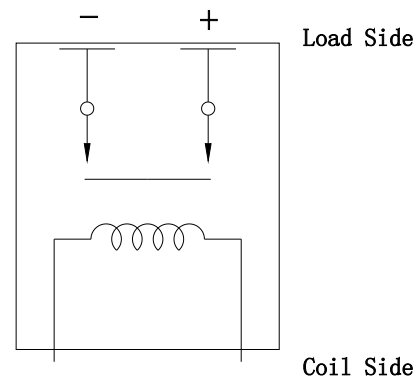

NOTE: The contacts are polarized

NOTES

●Mounting Attention

1. When installing the relay, always use washers to prevent the screws from loosening.
2. Tighten each screw within the rated range given in the outline dimensions. Exceeding the maximum torque may result in breakage.
3. Avoid mounting the relay in strong magnetic fields (near a transformer or magnet) or close to an object that radiates heat.

●Electrical Life Attention

1. This relay is a DC high-voltage switch. In its final breakdown mode, it may lose the ability to provide the proper cut-off. Therefore, do not exceed the indicated switching capacity and life.
2. Please treat the relay as a product with limited life and replace it when necessary.
3. The contacts of the relay are polarized. Please follow instructions in the connection schematic when connecting the contacts.
4. Be careful that foreign matter and oils and fats kind, don't stick to the main terminal parts because it is likely to cause terminal parts to give off unusual heat. Also, please use the following specifications of conductor.

10A	Min. 2mm ² nominal cross-sectional area
20A	Min. 3mm ² nominal cross-sectional area
40A	Min. 10mm ² nominal cross-sectional area
60A	Min. 15mm ² nominal cross-sectional area
100A	Min. 35mm ² nominal cross-sectional area
150A	Min. 45mm ² nominal cross-sectional area
200A	Min. 60mm ² nominal cross-sectional area
250A	Min. 80mm ² nominal cross-sectional area
300A	Min. 100mm ² nominal cross-sectional area

●Coil Attention

1. Please note that when using a diode, the switching speed may decrease and cause a reduction in cut-off performance, we recommend installing a surge protector varistor.
2. The pick-up voltage and drop-out voltage will change with ambient temperature, please use rated voltage to make sure the relay operate reliable. Don't exceed maximum coil voltage.
3. The 250A and 300A types have built-in dedicated drive circuit, please drive the coil with a quick startup (Built-in one-shot pulse generator circuit).
4. After the ON signal enters the 250A and 300A types, automatic coil current switching occurs after approximately 0.1 seconds. Do not repeatedly turn it OFF within that 0.1 seconds interval, as doing so may damage the relay.

Disclaimer:

This datasheet is the customers' reference. All the specification are subject to change without notice.

We could not evaluate all the performance and parameters for every possible application. Thus the users should be in a right position to choose the suitable product for their own application. If there is any query, please contact Sanyou for technical service. However it is the users' responsibility to determine which product should be used only.

SANYOU CORPORATION LIMITED. All rights reserved by Sanyou.